

CNP ECO SERIES

LIQUID NITROGEN GENERATION REIMAGINED FOR CRYOGENIC EXCELLENCE



The **CNPECO-2** is a cutting-edge liquid nitrogen generator with a production capacity of **480 liters/day**. Designed for maximum efficiency, this advanced system features a quick startup capability, accelerating the nitrogen liquefaction process and enhancing operational effectiveness. Its plug-and-play design and user-friendly interface make integration into any setup seamless, with one-button operation for ease of use. CNPECO-2 operates fully automatically under the guidance of an intelligent PLC.

Take control with the CNP Series' advanced *PLC interface*, which centralizes operations and offers real-time remote monitoring. Displaying system status live, it ensures high-quality Nitrogen production and reliable quality control. Real-time diagnostics and reporting provide valuable insights, enhancing operational efficiency. Remote monitoring reflects our commitment to innovation, delivering a seamless, high-purity Nitrogen supply.

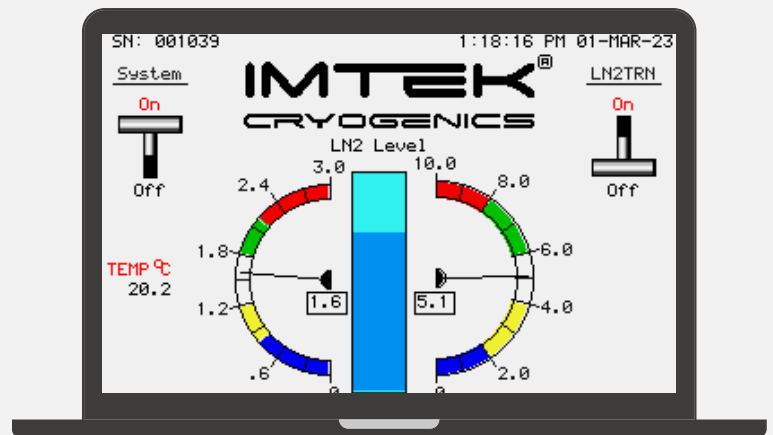

THE NITROGEN PRODUCTION PROCESS

Atmospheric air is compressed by an oil-free compressor and directed to a Buffer Tank, where high-pressure air is filtered to remove water droplets and particles. An internal air dryer then removes any remaining moisture, achieving a dew point of up to -40°C . The dry, clean air is directed into the Pressure Swing Adsorption (PSA) module, where carbon molecular sieves selectively adsorb oxygen and CO_2 to produce high-purity nitrogen.

PSA technology alternates between two adsorber beds: one bed adsorbs oxygen, while other depressurizes and purges. This cycle ensures continuous flow of pure nitrogen, which is stored in a nitrogen buffer tank and then directed to a cryogenic storage tank, complete with a cryocooler and associated instrumentation for efficient nitrogen liquefaction.

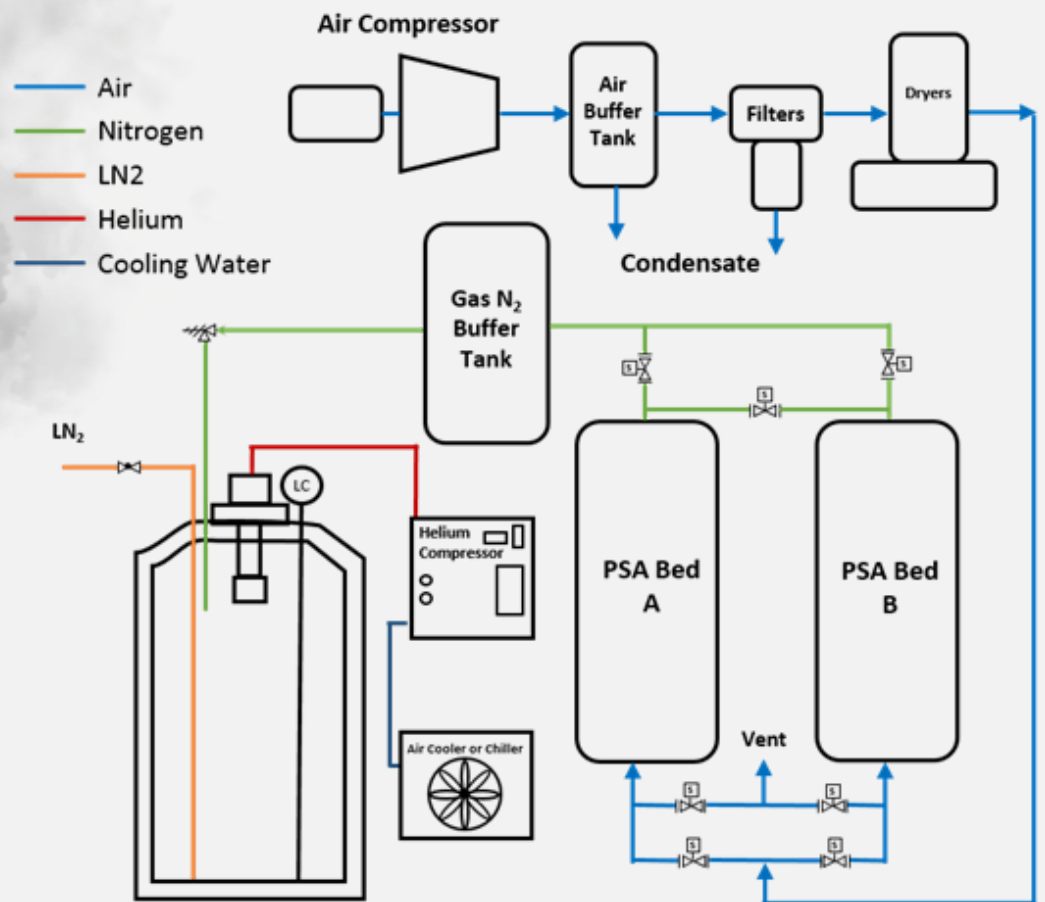

IMTEK INTELLIGENT INTERFACE

The **CNPECO-2** Nitrogen Generation and Storage System features a PLC interface with five essential screens for streamlined control. The Main screen acts as the central hub, offering start/stop controls, diagnostic mode, and pressure indicators. The Service screen enables monitoring of key components and includes multilingual options, while the Cryo-Service screen provides quick access to technical support.

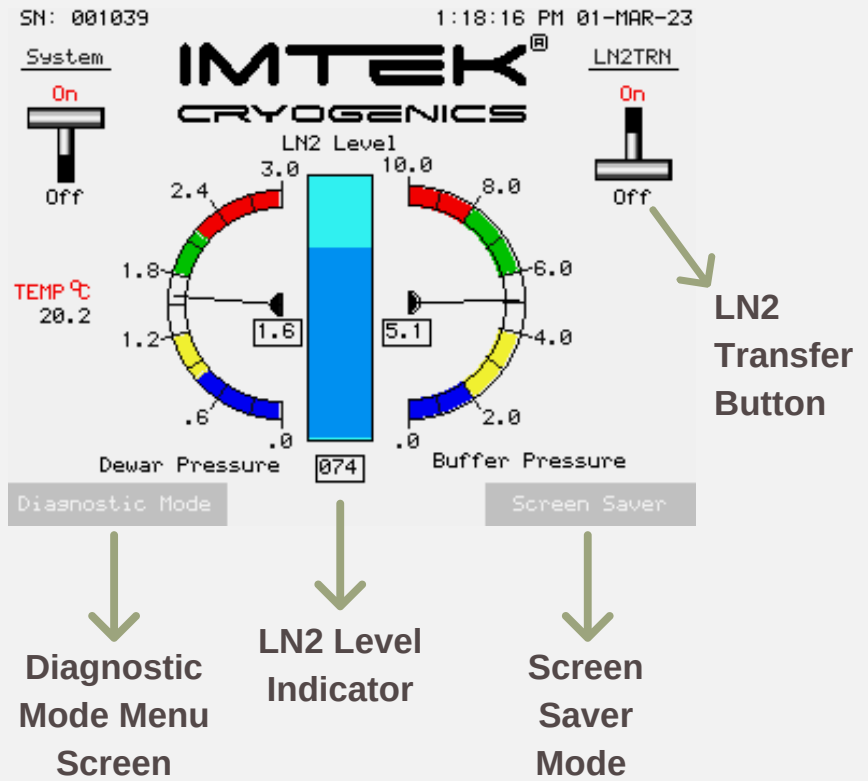

02:12:54 PM 24-MAY-23

Buffer AutoPurge	Dewar AutoPurge
Air Comp OFF 0.0	Air Pressure is LOW
Buffer Purge OFF 0.0	Dewar Purge OFF 0.0
Circulation Pump OFF	He Comp OFF
Chiller OFF	CNPTemp is HIGH 0.0
Restart Level: % 6	Air Comp 00000 h
	He Comp 00000 h

02 Lvl:
Dew P.:
Level: 0 dec.

English French Spanish

Home CryoService Alarm History Service

For maintenance, the Maintenance screen supports system purging and technical interventions, enhancing service efficiency. The Initialization screen guides users through setup and purging, automatically transitioning to the Main screen upon completion.

MODEL	CNPECO-2
Production Rate	≥ 480 liter/day @ 23 °C
Electrical Options	380-415 V (±10%) @50Hz V3~ 480 V (±10%) @60Hz V3~
Power Consumption (Steady State)	26.4 kW @50Hz 27.6 kW @60Hz
Dimensions (W x L x H)	1240x3300x1440 mm
Weight	1250-1500 kg
Suggested Min. Installation Area	5m (W) x 5m (L) x 4m (H)
Req. External Compressor	≥ 60 m ³ / hour @7 bar (102 psig)
Cryocooler	GM Type Cryocooler Mounted on Dewar
Compressor	He, 99.995% purity @ 19-19.3bar (275-280 psig), Air Cooled
Req. Cooling Water Flow Rate	24-36 L/min
Req. Chiller Capacity	~30 kW
Built-In Nitrogen Generator	
Purity	≥ 99.5%
Dew Point	up to -40°C
Flow Rate	≥ 20 m ³ / hour
PLC Interface	8" Color Graphic Touch Screen
Dewar Volume	500 Liters (1000 Liters Option)
Operating Pressure	1-1.8 bar
Dewar Level Control	Capacitive Level Sensor
Ambient Temperature Range (Inner Temperature)	+4°C to +40°C
Maximum Altitude	3000 meters
Noise Level	< 65 dB @ 1 meter
Conformities	CE Conformance, ISO 12100:2010, IEC 60204-1, 2006/42/EC, 97/23/EC; ISO9001:2015